

# Contents

<b>Warranty and Disclaimer</b>	2
<b>Introduction</b>	3
<b>Physical Dimensions</b>	
Board Layout	4
Servo connections	5
<b>Using the Serv8</b>	
Usage	6
Setting the start address	7
Setting the pulse width	8
Pulse width jumpers	9
Using the configuration jumpers	10
Using the PC Serial Port	12
<b>Troubleshooting</b>	
Ground, termination, LED	13
Erratic output, misc.	
<b>Using RC Servos</b>	15
<b>Using DMX512</b>	
Splitters, terminators	17
Wire type, cable length, connectors	
Diagram of DMX 512 cable routing	19
Mini DIP address settings	20
1-256	
257-512	21



## ***Warranty and Disclaimer***

### **Warranty**

Northlight Systems warrants this product against defects in materials and workmanship for a period of 1 year.

If the board is defective, we will, at our option, repair or replace the product. We offer a full refund on the purchase price if returned in original condition in less than 30 days.

Return the product with a description of the problem. We will return your item or its replacement using the same shipping method used to ship the product originally.

### **Disclaimer of Liability**

Northlight Systems is not responsible for any special, incidental, or consequential damages resulting for any breach of warranty, or any legal theory, including lost profits, downtime, goodwill, damage to or replacement of equipment or property, and any costs associated with the use of Northlight Systems products described herein.

Northlight Systems has a policy of continually improving our products as new technology becomes available. Northlight Systems reserves the right to make changes and improvements to the specifications of this equipment at any time without notice.

Northlight Systems has made every attempt to ensure that the information in this document is accurate and complete. Northlight Systems assumes no liability for any damages that result from the use of this manual or the equipment it documents. Northlight Systems reserves the right to make changes to this document at any time without notice.

### **Contact**

Northlight Systems  
1247 E. Valerie Drive  
Tempe, AZ 85281

Voice 480 429-0577  
Fax 480 949-2625

## **8 Channel, DMX to RC servo controller board**

### **Features**

- Allows DMX512 digital protocol to control 8 – RC type servos.
- 255 positions across the output range.
- All outputs on standard 3 terminal, .10” , “Futaba” style connectors.
- Mini DIP address switch, address 512 channels.
- On board voltage regulator for controller power.
- Separate connectors for board power and servo power.
- 8 - Selectable output pulse widths.

### **SPECS**

#### **Input Signal**

Northlight Serv8 board accepts DMX512 - 1990 as specified by USITT. The Serv8 board can receive data at the full rate. The decoder is responsive to all 512 channels.

#### **PC Serial port**

Mini SSC protocol @9600 BPS..

#### **Output**

Default output is 8 PWM channels @ 1 to 2 milliseconds. Update rate @ 50Hz. Output pulse has 255 discrete positions.

#### **Address switch**

9 position mini DIP switch.

#### **Power requirements**

8 to 12 volts DC @ 90 mA. for controller board. Servo power is separate.

#### **LED Indicators:**

Red power LED.

#### **Board connections**

All outputs use standard 3 pin, 0.10”, “Futaba” connectors. See drawing for connector locations.

Power and DMX512 signals use screw terminals.

**Physical Dimensions**

2.30”L X 1.30”W +/- .10”

The **DMX input** pin numbers correspond to the XLR pin numbers.

DMX512 ,Pin 1 is signal ground – not earth ground.

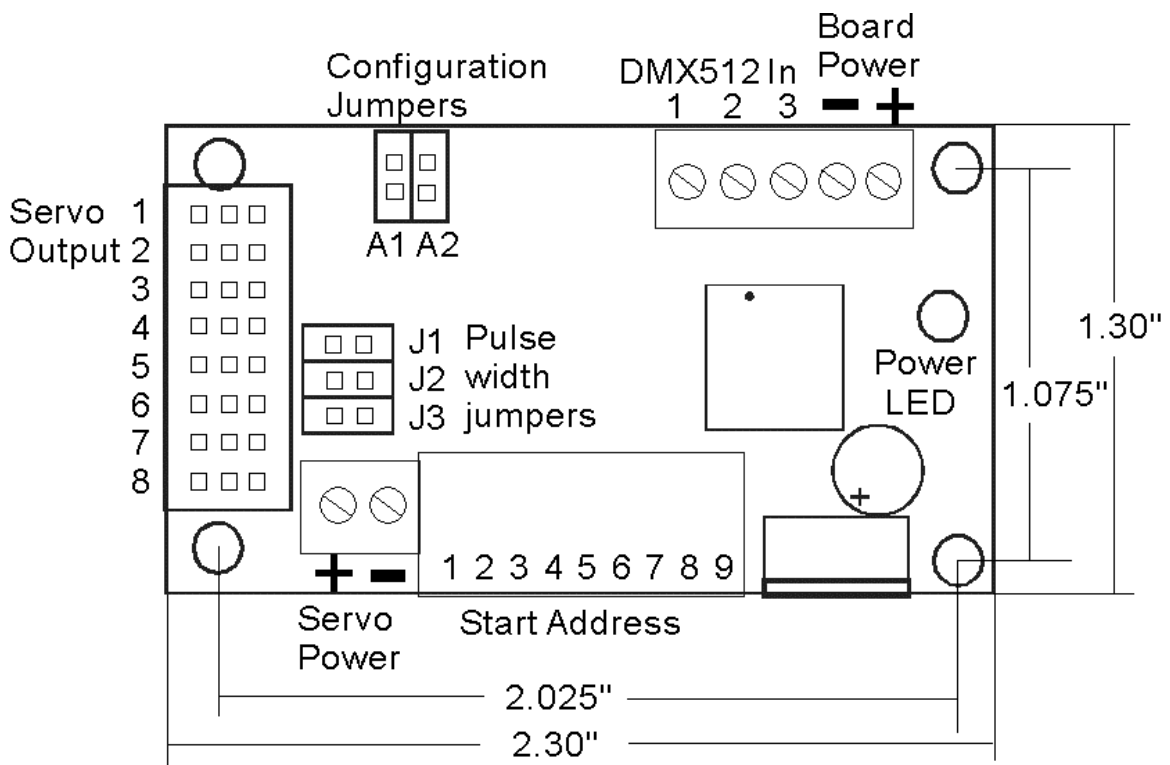

**Servo connections**

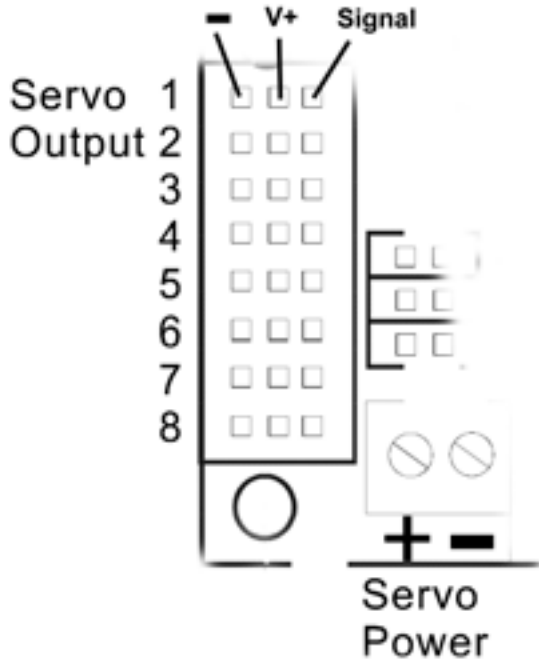

The servo power and signal pins are arranged as shown in the drawing.

This is standard for Futaba and most RC servos.

The power for the servos is separate from the controller power. The - gnd is common to the controller power connector.

- Futaba – 1. White = signal
- 2. Red = positive
- 3. Black = negative

- HiTec, Tower, Airtronic “Z” –
- 1. White = signal
- 2. Red = positive
- 3. Black = negative

- Airtronics standard -
- 1. Black = signal
- 2. Black = negative
- 3. Black/stripe = signal

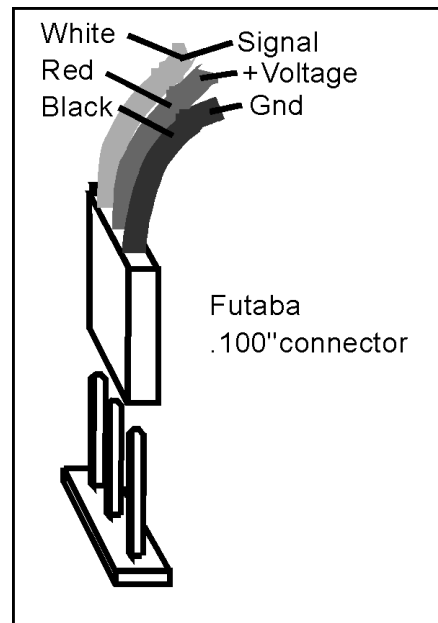

## Using the Serv8

### **Power Input**

7.5 to 12 volts DC @ 90 mA. for the controller only. On average the current consumption is around 60 mA.

There is a separate connector for the servo power supply. The voltage and current for the servos is dependent on the servo type and load.

### **Output Pulse Width**

The default output is from 1 to 2 milliseconds @ 50 Hz. By using the configuration jumpers, the output pulse width can be increased or decreased. See the section on setting the pulse width for a chart of the settings. There are 255 discrete servo positions for all pulse widths.

### **DMX512 In**

The DMX input pin numbers correspond to the XLR pin numbers.

Pin 1 is signal ground , not earth ground

Pin 2 is DMX512 +

Pin 3 is DMX512 -

### **Ground**

The DMX512 signal ground is the common signal ground – not earth ground. Do Not connect DMX pin 1 to earth ground.

Do not connect the servo power supply to earth ground. This will connect the DMX pin 1 to earth ground, through the controller power supply.

### **Address Switch**

The individual switches are numbered 1 – 9, left to right.

The address is set according to the chart at the back of this manual.

The address switch is scanned by the controller around every 50 seconds. There is a noticeable delay after the switches are set, until the change is seen. This is true for the pulse width jumpers as well.

## Setting the Start Address

Set the starting address to the first in a group of 8.  
The address is entered on the DIP switches in standard binary code starting with 0.

See the chart of all 512 address switch positions at the back of this manual.

Once the address is set it should not be cleared.

## Setting the Pulse width

The Serv8 board is capable of 8 pulse widths. The most common is a pulse of 1-2 milliseconds @ 50Hz. On most servos this produces 90 degrees of movement. This is the default setting when shipped.

The maximum pulse width produces about 180 degrees of movement. Some servos don't have this much travel and may be damaged.

Be careful when using the longer pulse widths. If the servo "chatters" the pulse width is too wide.

The table below shows the 8 pulse widths.

Jumpers            Min pulse width    Max pulse width    Pulse range

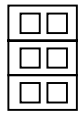

J1  
J2  
J3

1.25 mS

1.75 mS

0.50 mS

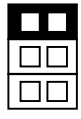

J1  
J2  
J3

1.20 mS

1.80 mS

0.70 mS

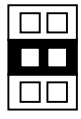

J1  
J2  
J3

1.10 mS

1.90 mS

0.80 mS



J1  
J2  
J3

1.00 mS

2.00 mS

1.00 mS

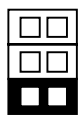

J1  
J2  
J3

0.90 mS

2.10 mS

1.20 mS

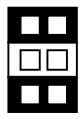

J1  
J2  
J3

0.80 mS

2.13 mS

1.33 mS

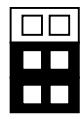

J1  
J2  
J3

0.70 mS

2.18 mS

1.48 mS



J1  
J2  
J3

0.60 mS

2.21 mS

1.61 mS

## Using the configuration jumpers

There are 2 configuration jumpers on the Serv8.

**A1** – Determines the output in the event of DMX signal loss.  
This function is not affected by the A2 setting.

**Open**(no jumper) – When the DMX signal is lost the Serv8 will hold and continue to output the last valid data.  
This is the default setting.

**Closed**(jumper in place) – When the DMX signal is lost, the servo's will go to the center position.

**A2** – Determines the control signal protocol. This jumper is only checked once when the power is first applied. Changing the jumper setting will not take effect until the power has been cycled off and on.

**Open**(no jumper) – the Serv8 is configured to receive DMX512.  
This is the default setting.

**Closed**(both jumpers in place) – The serv8 is configured to receive Mini SSC protocol from a PC serial port @ 9600 baud.

## Setting up the DMX connectors

The current DMX512 standards require one to provide passive loop through connectors.

The specific description is below:

### Secondary data link - passive loop through ports

Devices containing two DMX512 ports, one for receive and one for transmit, that do not actively process or buffer data, shall provide a direct passive link for all pins between the two ports.

Devices containing three or more DMX512 ports may provide a passive link between only two of the ports.

Equipment designers are encouraged to provide passive loop through on Pins 4 and 5 whenever possible, even if not required.

The drawing below shows a typical installation.

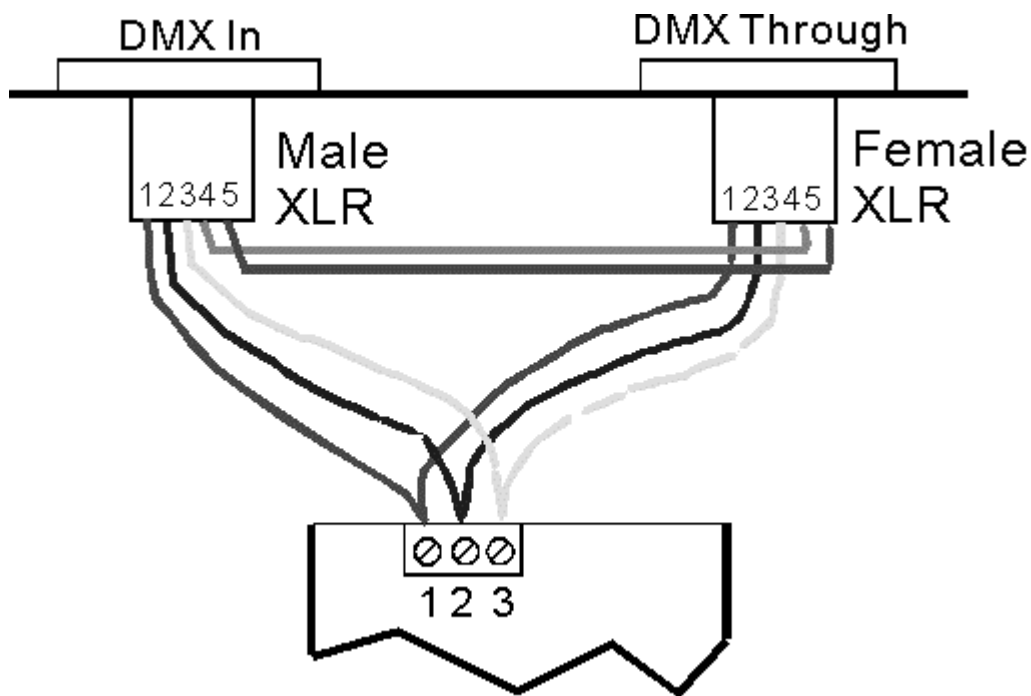

## Using the PC serial port

The Serv8 board can accept 9600-baud data from a PC serial port. The protocol used is compatible with a number of servo controllers including Scott Edwards's mini SSC servo controller. There are several commercial animatronics software packages available for a servo controllers using this protocol.

A freeware Visual Basic package is available on the Northlight web site. It was originally on the PARTS (Portland area robotics society) web site.

### Selecting PC serial mode

The SIP jumper must be shorted for PC serial mode.

The Serv8 board is shipped in DMX mode, with the SIP header open. When the jumper is changed it will not take effect until after the power to the board cycled off and on.

### Mini SSC protocol

To send a new position command, 3 bytes are needed.

The first is a "sync" byte with a value of 255.

The second byte is the servo address. It is a number from 0 to 254.

The third byte is the actual position data, between 0 and 254.

This sequence is followed for each servo position.

### Connections:

Only 2 wires are needed from the PC serial port.

PC ground is connected to DMX input 1.

The RS232 signal is connected to DMX input 2.

The standard PC computer DB-9 connector:

Pin 3 = Serial data

Pin 5 = Signal ground

## Trouble shooting

Basically the board is plug and play. When all connections are properly made, an variable pulse, proportional to the input signal will be present at the output pins.

### Signal Ground/common

On the board, there is NO connection between chassis/earth ground and Signal/common ground. Do not install one.

On the DMX data cable, there is NO connection between the shield/XLR shell earth ground and the signal/common ground. Do not connect these together.

### Termination

Northlight's Serv8 does not contain a terminating resistor. It is up to the user to determine the termination requirements. If the Serv8 board is the last one on the DMX link a 120 terminating resistor can be installed on the DMX input connector, across pins 2 – 3.

It is possible to “over terminate”. In other words make sure there is only 1 terminator on the end of the DMX line. Some devices have internal terminators, double check the settings.

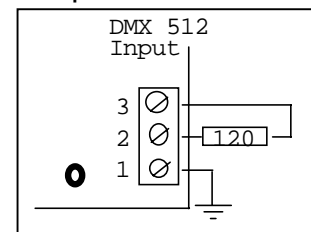

### PC Serial Port

If you have hooked up the SERV8 to your computer and it doesn't seem to respond to the keyboard, the first thing to check is that you are attached to the right serial port. The easiest way to do this is to disconnect the SERV8 and short between the Tx data out and Rx data in pins on the serial port connector on the back of your computer. On all IBMs and compatibles this means sticking a piece of wire, paper clip, or similar tool between pins 2 and 3 on the 'Com.' connector. While running a modem program, anything you type should be shown on the screen while this paper clip is in place, while nothing will appear when you remove it. If your computer passes this test, then you are using the right serial port and the problem is most likely the baud rate setting or in your wiring to the SERV8. If you get characters on the screen even with the paper clip removed from the serial port, it means you probably need to set the 'echo' mode to 'none' or 'full duplex' and try this test again.

### Red Power LED

Double check the input power by using a multimeter on the screw terminals of the input power connector. If the red LED is out the power supply may be defective.

**No output**

Check the signal wires as noted above.

Be sure the address is set to a valid address. The Serv8 start address should not be higher than the highest address received. The mini DIP switch is marked on and off.

**PC mode** Make sure the jumper is set for PC mode, cycle the power to be sure it is reset.

**Erratic output**

This problem can be hard to track down.

*First* check the input signal integrity. There should be signal present on both Data lines for DMX512. Reverse the connections.

In PC mode make sure there is no terminating resistor.

Make sure the pulse width is not too long for that servo. Servos will “chatter” if the pulse is too long.

A weak power supply can cause a similar problem. Remove any load from the servo. If it still chatters the problem is possibly not the power supply.

**Misc**

Good solid connections are a must. The mini screw terminals provide good connections. However the screws can be stripped by over tightening. DMX512 signal wires should be twisted together all the way to the connector. It is recommended that a separate power supply be used to power the Serv8 board. Occasionally unexpected problems can occur if power is “borrowed” from another source. Small wall wart transformers work well for this application.

## Using RC Servos

Remote control-style Servo motors have built-in amplifiers and position feedback sensors so that all they need is a power supply and the pulse width modulated control signal to operate. The pulse width for the control signal is usually between 1.0 milliseconds and 2.0 milliseconds at a frequency of 50 times per second.

A servo arm takes a certain amount of time to move from one position to another. This is the “slew” time. Most hobby servo’s are pretty slow, usually in the range of .50 second to travel 90 degrees of rotation. Faster servos usually cost more and require more power.

Even the fastest servos can’t move fast enough to keep up with the update rate of the Serv8 receiving DMX512.

The output ‘swing’ can be adjusted to allow a full 180 degrees of movement on most servo motors. This usually requires a pulse longer than the nominal 1 to 2 millisecond(MS). When going to the longer pulse widths, do so in steps.

Overdriving the servo with too long a pulse can ruin the motor.

Servo motors require a separate, larger power supply. Typical Servo motors run on voltages of 3 to 24 volts DC, common hobby servo use 9 VDC, and depending on the Servo and its load, can draw several amps of current. Most small Servo motors are powered through the same three conductor ‘F’ or ‘Futaba’ connector that is used to send them their control signal. Some larger Servo motors, like the ‘Tone’, ‘Condor’, or CK Designs Servo motors have separate twelve or twenty-four volt power supply connections in addition to the three conductor control cable.

### Servo PWM control signals

Most servos require a variable width pulse from 1 to 2 milliseconds(Ms) long, at a rate of about 50 times per second.

Northlights Serv8 outputs a pulse at about 50 HZ.

The servos are pulsed 1 at a time, in sequence, as illustrated in the drawing below. Some servo controllers will start the pulse for the next servo immediately after completing the current pulse. This has the effect of varying the pulse rate, as determined by the pulse widths. This is an unacceptable situation as the motor behavior can be erratic.

The Serv8 always uses an equalizing delay after the control pulse to keep the update rate constant, regardless of the actual motor pulse widths.

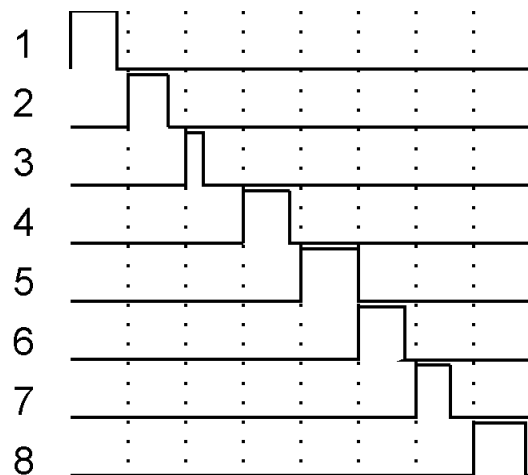

**Servo Motor Power:** Screw terminals are used to connect the power supply for the servo motors. Five to Nine volts is typical for most small servo motors . The current draw on most Servo motors is at least an amp. Some larger Servo motors can draw far more. For most average sized Servo motors, if you allow half an amp per motor you will probably be safe. You can tell if you are drawing too much power if the Servo motors start interacting.

The servo connectors are male headers on .1” centers, arranged in the ‘F’ or ‘Futaba’ style. The three pins used by each Servo motor are as follows:

1) Ground (outside edge of the board): This is usually a black wire. This pin is connected directly to the Servo motor ground screw terminal. All Servo motors use the same ground.

2) Servo motor Power(center pin): This is usually a red wire. This pin is connected directly to the Servo motor Power screw terminal. All Servo motors use the same power.

3) Control Signal(inside pin): This is usually white wire. This is the pulse width modulated control signal for the Servo motor.

There is nothing to keep you from plugging these pins in backwards or with reversed polarity, so be careful when attaching the Servo.

---

## Using DMX512

DMX 512 is a digital communications protocol that specifies a set of requirements for transmitting and receiving digital signals between lighting controllers and dimmers. There are 2 main components to this spec. The Data Protocol is the meaning of the bits and bytes that are transmitted. Northlight's Decoder is compliant with the full requirements of the Data Protocol. There is a certain amount of flexibility in the signal timing, Northlight's Decoder is capable of receiving data at the full data rate specified.

The other component of DMX512 is the Electrical Specifications. The hardware electrical specs are listed in EIA-485, commonly referred to as the RS-485 specs. The RS-485 standard, specifies only the electrical characteristics of the driver and the receiver to be used at the line interface. Northlight's Decoder is compliant with RS-485. Each Decoder represents less than 1 node load to the system.

RS485 is a data transmission system using balanced differential signals. That is 2 signal wires and signal ground. 3 wires are required.

### **Splitters/Repeaters**

Isolation between the console and dimmers is sometimes required to prevent signal degradation and protect devices from damaging voltages on the control cable. Optically isolated splitters help avoid these problems.

Each DMX512 output can drive up to 32 devices. If there are more devices on the line, a "repeater" or "booster" is required.

Long or improper cables, electrically noisy environment (generators, motors) and improper use of passive "Y" splitters all contribute to DMX signal degradation. A repeater/booster may help to solve these problems.

### **Why ask WYE?**

Wye(Y) splitters are NOT recommended for DMX512 systems. Wye splitters are simply a male inline XLR connector, parallel wired to 2 female inline XLR's. While convenient, Wye splitters cause unwanted signal reflections and possible ground loops, leading to signal degradation.

The best layout for DMX systems is a Daisy chain configuration, where the signal cable jumps from one device to the next, with no branching. Each chain can have up to 32 devices on it. When using an isolated splitter, each outputs can be a separate DMX daisy chain.

### **Termination**

A common problem with DMX systems is improper termination.

A simple terminator consists of a 120 Ohm resistor connected across pins 2-3 of the DMX signal. More complex terminators utilize voltage spike protection and bi-color LEDs to indicate signal integrity.

Terminators are an impedance matching circuit required to damp signals that "reflect" from the end of an improperly terminated cable, causing signal degradation under certain conditions.

On devices that have a DMX thru, a male XLR connector with terminating resistor connected across pins 2-3 and installed on the DMX thru connector will suffice. Some devices with isolated outputs will not use a terminator on the DMX out. These usually have an internal terminator that is selected with a switch.

**Wire Type**

There is a difference between microphone cable and “Data” cable. Sure you can get away with mic. cable for short runs in many situations. However on longer runs or marginal situations mic. cable will let you down. You may have random errors or the system won’t work at all. It comes down to insurance. If you want to insure the most reliable DMX signal distribution you need the most appropriate wire for the job. DMX512 requires wire suitable for RS-485, there is no way to get around that.

Twisted-pair cable is the most common wire type. You can use a range of wire gauges, most frequently use 22 – 24 AWG. The characteristic impedance of the cable should be 100 to 120 Ohms.

Some other requirements are, at least 1 twisted pair plus ground and shield. It should have low capacitance and overall braid and foil shield.

**Data Rate VS Cable Length**

At 250K bits per second the max cable length is about 1000 ft for DMX512 in good conditions.

**Connectors**

DMX512 protocol specifies that 5 pin XLR connectors be used. Female on the transmitter and male on the receiver.

When a 3 pin XLR is used it is wired the same as the first 3 pins on the 5 pin XLR.

<b>PIN</b>	<b>WIRE</b>	<b>SIGNAL</b>
1	shield	ground/return
2	signal	data compliment ( - )
3	signal	data true ( + )
4	signal	spare data compliment ( - )
5	signal conductor	spare data true ( + )

Conductors 2/3 and 4/5 should be twisted together.

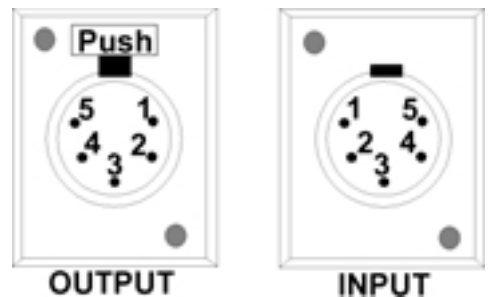

## Typical DMX signal routing

Simple setup

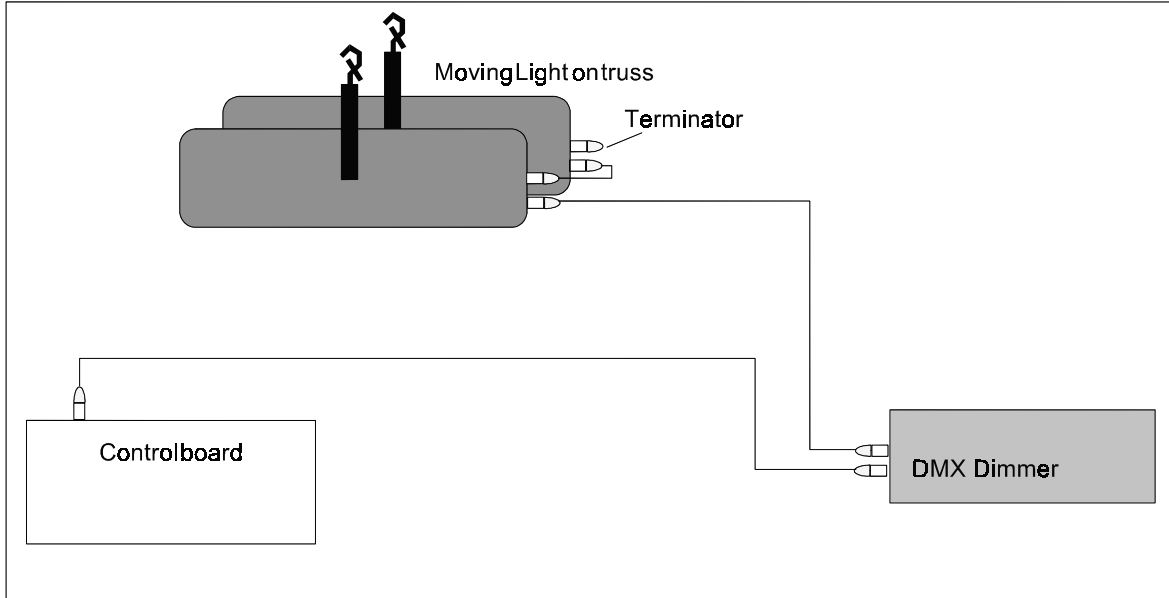

A more complicated setup. The Isolated splitter greatly simplifies cable routing and keeps individual runs short.

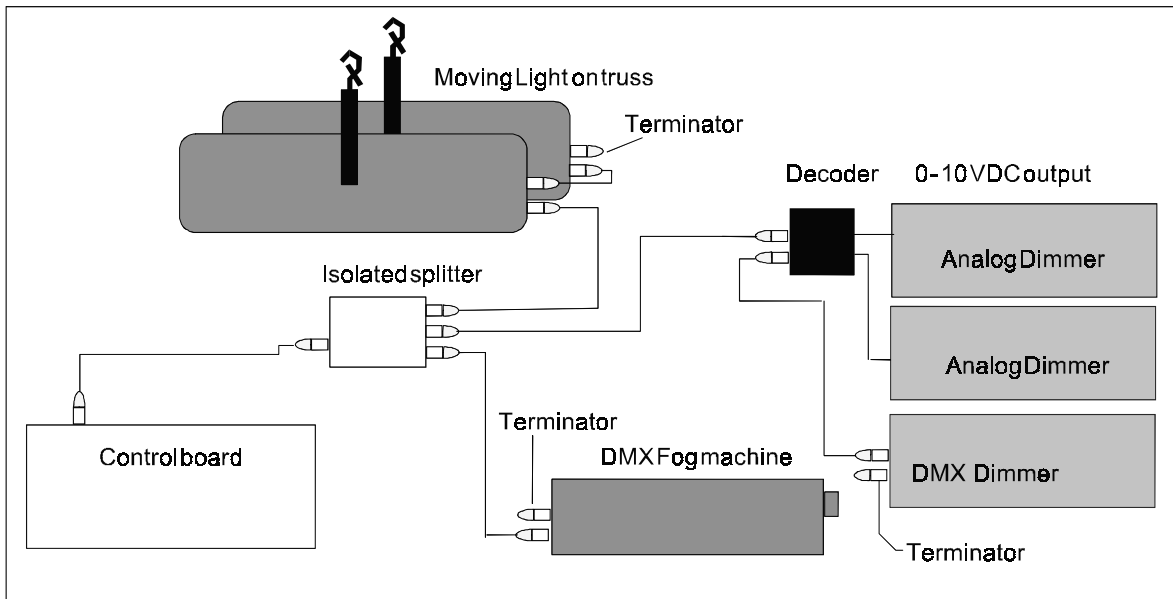

# NORTHLIGHT SYSTEMS

## Ch# Dip Switch On

1 = 0  
 2 = 1  
 3 = 2  
 4 = 1,2  
 5 = 3  
 6 = 1,3  
 7 = 2,3  
 8 = 1,2,3  
 9 = 4  
 10 = 1, 4  
 11 = 2,4  
 12 = 1,2,4  
 13 = 3,4  
 14 = 1,3,4  
 15 = 2,3,4  
 16 = 1,2,3,4  
 17 = 5  
 18 = 1,5  
 19 = 2, 5  
 20 = 1,2,5  
 21 = 3,5  
 22 = 1,3,5  
 23 = 2,3,5  
 24 = 1,2,3,5  
 25 = 4,5  
 26 = 1,4,5  
 27 = 2,4,5  
 28 = 1,2,4,5  
 29 = 3,4,5  
 30 = 1,3,4,5  
 31 = 2,3,4,5  
 32 = 1,2,3,4,5  
 33 = 6  
 34 = 1,6  
 35 = 2,6  
 36 = 1,2,6  
 37 = 3,6  
 38 = 1,3,6  
 39 = 2,3,6  
 40 = 1,2,3,6  
 41 = 4,6  
 42 = 1,4,6  
 43 = 2,4,6  
 44 = 1,2,4,6  
 45 = 3,4,6  
 46 = 1,3,4,6  
 47 = 2,3,4,6  
 48 = 1,2,3,4,6  
 49 = 5,6  
 50 = 1,5,6  
 51 = 2,5,6  
 52 = 1,2,5,6  
 53 = 3,5,6  
 54 = 1,3,5,6  
 55 = 2,3,5,6  
 56 = 1,2,3,5,6  
 57 = 4,5,6  
 58 = 1,4,5,6  
 59 = 2,4,5,6  
 60 = 1,2,4,5,6  
 61 = 3,4,5,6  
 62 = 1,3,4,5,6  
 63 = 2,3,4,5,6  
 64 = 1,2,3,4,5,6

## Ch# Dip Switch On

65 = 7  
 66 = 1,7  
 67 = 2,7  
 68 = 1,2,7  
 69 = 3,7  
 70 = 1,3,7  
 71 = 2,3,7  
 72 = 1,2,3,7  
 73 = 4,7  
 74 = 1,4,7  
 75 = 2,4,7  
 76 = 1,2,4,7  
 77 = 3,4,7  
 78 = 1,3,4,7  
 79 = 2,3,4,7  
 80 = 1,3,4,7  
 81 = 5,7  
 82 = 1,5,7  
 83 = 2,5,7  
 84 = 1,2,5,7  
 85 = 3,5,7  
 86 = 1,3,5,7  
 87 = 2,3,5,7  
 88 = 1,2,3,5,7  
 89 = 4,5,7  
 90 = 1,4,5,7  
 91 = 2,4,5,7  
 92 = 1,2,4,5,7  
 93 = 3,4,5,7  
 94 = 1, 3,4,5,7  
 95 = 2,3,4,5,7  
 96 = 1,2,3,4,5,7  
 97 = 6,7  
 98 = 1,6,7  
 99 = 2,6,7  
 100 = 1,2,6,7  
 101 = 3,6,7  
 102 = 1,3,6,7  
 103 = 2,3,6,7  
 104 = 1,2,3,6,7  
 105 = 4,6,7  
 106 = 1,4,6,7  
 107 = 2,4,6,7  
 108 = 1,2,4,6,7  
 109 = 3,4,6,7  
 110 = 1,3,4,6,7  
 111 = 2,3,4,6,7  
 112 = 1,2,3,4,6,7  
 113 = 5,6,7  
 114 = 1,5,6,7  
 115 = 2,5,6,7  
 116 = 1,2,5,6,7  
 117 = 3,5,6,7  
 118 = 1,3,5,6,7  
 119 = 2,3,5,6,7  
 120 = 1,2,3,5,6,7  
 121 = 4,5,6,7  
 122 = 1,4,5,6,7  
 123 = 2,4,5,6,7  
 124 = 1,2,4,5,6,7  
 125 = 3,4,5,6,7  
 126 = 1,3,4,5,6,7  
 127 = 2,3,4,5,6,7  
 128 = 1,2,3,4,5,6,7

## Ch# Dip Switch On

129 = 8  
 130 = 1,8  
 131 = 2,8  
 132 = 1,2,8  
 133 = 3,8  
 134 = 1,3,8  
 135 = 2,3,8  
 136 = 1,2,3,8  
 137 = 4,8  
 138 = 1,4,8  
 139 = 2,4,8  
 140 = 1,2,4,8  
 141 = 3,4,8  
 142 = 1,3,4,8  
 143 = 2,3,4,8  
 144 = 1,2,3,4,8  
 145 = 5,8  
 146 = 1,5,8  
 147 = 2,5,8  
 148 = 1,2,5,8  
 149 = 3,5,8  
 150 = 1,3,5,8  
 151 = 2,3,5,8  
 152 = 1,2,3,5,8  
 153 = 4,5,8  
 154 = 1,4,5,8  
 155 = 2,4,5,8  
 156 = 1,2,4,5,8  
 157 = 3,4,5,8  
 158 = 1,3,4,5,8  
 159 = 2,3,4,5,8  
 160 = 1,2,3,4,5,8  
 161 = 6,8  
 162 = 1,6,8  
 163 = 2,6,8  
 164 = 1,2,6,8  
 165 = 3,6,8  
 166 = 1,3,6,8  
 167 = 2,3,6,8  
 168 = 1,2,3,6,8  
 169 = 4,6,8  
 170 = 1,4,6,8  
 171 = 2,4,6,8  
 172 = 1,2,4,6,8  
 173 = 3,4,6,8  
 174 = 1,3,4,6,8  
 175 = 2,3,4,6,8  
 176 = 1,2,3,4,6,8  
 177 = 5,6,8  
 178 = 1,5,6,8  
 179 = 2,5,6,8  
 180 = 1,2,5,6,8  
 181 = 3,5,6,8  
 182 = 1,3,5,6,8  
 183 = 2,3,5,6,8  
 184 = 1,2,3,5,6,8  
 185 = 4,5,6,8  
 186 = 1,4,5,6,8  
 187 = 2,4,5,6,8  
 188 = 1,2,4,5,6,8  
 189 = 3,4,5,6,8  
 190 = 1,3,4,5,6,8  
 191 = 2,3,4,5,6,8  
 192 = 1,2,3,4,5,6,8

## Ch# Dip Switch On

193 = 7,8  
 194 = 1,7,8,  
 195 = 2,7,8,  
 196 = 1,2,7,8  
 197 = 3,7,8  
 198 = 1,3,7,8  
 199 = 2,3,7,8  
 200 = 1,2,3,7,8  
 201 = 4,7,8,  
 202 = 1,4,7,8  
 203 = 2,4,7,8  
 204 = 1,2,4,7,S  
 205 = 3,4,7,8  
 206 = 1,3,4,7,8  
 207 = 2,3,4,7,8  
 208 = 1,2,3,4,7,8  
 209 = 5,7,8  
 210 = 1,5,7,8  
 211 = 2, 5,7,8  
 212 = 1,2,5,7,8  
 213 = 3,5,7,8  
 214 = 1,3,5,7,8  
 215 = 2,3,5,7,8  
 216 = 1,2,3,5,7,8  
 217 = 4, 5,7, 8  
 218 = 1,4,5,7,S  
 219 = 2,4,5,7,8  
 220 = 1,2,4,5,7,8  
 221 = 3,4,5,7,8  
 222 = 1,3,4,5,7,8  
 223 = 2,3,4,5,7,8  
 224 = 1,2,3,4,5,7,8  
 225 = 6,7,8  
 226 = 1,6,7,8  
 227 = 2,6,7,8  
 228 = 1,2,6,7,8  
 229 = 3,6,7,8  
 230 = 1,3,6,7,8  
 231 = 2,3,6,7,8  
 232 = 1,2,3,6,7,8  
 233 = 4,6,7,8  
 234 = 1,4,6,7,8  
 235 = 2,4,6,7,S  
 236 = 1,2,4,6,7,8  
 237 = 3,4,6,7,8  
 238 = 1,3,4,6,7,8  
 239 = 2,3,4,6,7,8  
 240 = 1,2,3,4,6,7,8  
 241 = 5,6,7,8  
 242 = 1,5,6,7,8  
 243 = 2,5,6,7,8  
 244 = 1,2,5,6,7,8  
 245 = 3,5,6,7,8  
 246 = 1,3,5,6,7,8  
 247 = 2,3,5,6,7,8  
 248 = 1,2,3,5,6,7,8  
 249 = 4,5,6,7,8  
 250 = 1,4,5,6,7,8  
 251 = 2,4,5,6,7,8  
 252 = 1,2,4,5,6,7,8  
 253 = 3,4,5,6,7,8  
 254 = 1,3,4,5,6,7,8  
 255 = 2,3,4,5,6,7,8  
 256 = 1,2,3,4,5,6,7,8

Ch#	Dip Switch On	Ch#	Dip Switch On	Ch#	Dip Switch On	Ch#	Dip Switch On
257	= 9	321	= 7,9	385	= 8,9	449	= 7,8,9
258	= 1,9	322	= 1,7,9	386	= 1,8,9	450	= 1,7,8,9
259	= 2,9	323	= 2,7,9	387	= 2,8,9	451	= 2,7,8,9
260	= 1,2,9	324	= 1,2,7,9	388	= 1,2,8,9	452	= 1,2,7,8,9
261	= 3,9	325	= 3,7,9	389	= 3,8,9	453	= 3,7,8,9
262	= 1,3,9	326	= 1,3,7,9	390	= 1,3,8,9	454	= 1,3,7,8,9
263	= 2,3,9	327	= 2,3,7,9	391	= 2,3,8,9	455	= 2,3,7,8,9
264	= 1,2,3,9	328	= 1,2,3,7,9	392	= 1,2,3,8,9	456	= 1,2,3,7,8,9
265	= 4,9	329	= 4,7,9	393	= 4,8,9	457	= 4,7,8,9
266	= 1, 4, 9	330	= 1,4,7,9	394	= 1,4,8,9	458	= 1,4,7,8,9
267	= 2,4,9	331	= 2,4,7,9	395	= 2,4,8,9	459	= 2,4,7,8,9
268	= 1,2,4,9	332	= 1,2,4,7,9	396	= 1,2,4,8,9	460	= 1,2,4,7,8,9
269	= 3,4,9	333	= 3,4,7, 9	397	= 3,4,8,9	461	= 3,4,7,8,9
270	= 1,3,4,9	334	= 1,3,4,7,9	398	= 1,3,4,8,9	462	= 1,3,4,7,8,9
271	= 2,3,4,9	335	= 2,3,4,7,9	399	= 2,3,4,8,9	463	= 2,3,4,7,8,9
272	= 1,2,3,4,9	336	= 1,2,3,4,7,9	400	= 1,2,3,4,8,9	464	= 1,2,3,4,7,8,9
273	= 5,9	337	= 5,7,9	401	= 5,8,9	465	= 5,7,8,9
274	= 1,5,9	338	= 1,5,7,9	402	= 1,5,8,9	466	= 1,5,7,8,9
275	= 2, 5, 9	339	= 2,5,7,9	403	= 2,5,8,9	467	= 2,5,7,8,9
276	= 1,2,5,9	340	= 1,2,5,7,9	404	= 1,2,5,8,9	468	= 1,2,5,7,8,9
277	= 3,5,9	341	= 3,5,7,9	405	= 3,5,8,9	469	= 3,5,7,8,9
278	= 1,3,5,9	342	= 1,3,5,7,9	406	= 1,3,5,8,9	470	= 1,3,5,7,8,9
279	= 2,3,5,9	343	= 2,3,5,7,9	407	= 2,3,5,8,9	471	= 2,3,5,7,8,9
280	= 1,2,3,5,9	344	= 1,2,3,5,7,9	408	= 1,2,3,5,8,9	472	= 1,2,3,5,7,8,9
281	= 4,5,9	345	= 4,5,7,9	409	= 4,5,8,9	473	= 4,5,7,8,9
282	= 1,4,5,9	346	= 1,4,5,7,9	410	= 1,4,5,8,9	474	= 1,4,5,7,8,9
283	= 2,4,5,9	347	= 2,4,5,7,9	411	= 2,4,5,8,9	475	= 2,4,5,7,8,9
284	= 1,2,4,5,9	34B	= 1,2,4,5,7,9	412	= 1,2,4,5,8,9	476	= 1,2,4,5,7,8,9
285	= 3,4,5,9	349	= 3,4,5,7,9	413	= 3,4,5,8,9	477	= 3,4,5,7,8,9
286	= 1,3,4,5,9	350	= 1,3,4,5,7,9	414	= 1,3,4,5,8,9	478	= 1,3,4,5,7,8,9
287	= 2,3,4,5,9	351	= 2,3,4,5,7,9	415	= 2,3,4,5,8,9	479	= 2,3,4,5,7,8,9
288	= 1,2,3,4,5,9	352	= 1,2,3,4,5,7,9	416	= 1,2,3,4,5,8,9	480	= 1,2,3,4,5,7,8,9
289	= 6,9	353	= 6,7,9	477	= 6,8,9	481	= 6,7,8,9
290	= 1,6,9	354	= 1,6,7,9	418	= 1,6,8,9	482	= 1,6,7,8,9
291	= 2,6,9	355	= 2,6,7,9	419	= 2,6,8,9	483	= 2,6,7,8,9
292	= 1,2,6,9	356	= 1,2,6,7,9	420	= 1,2,6,8,9	484	= 1,2,6,7,8,9
293	= 3,6,9	357	= 3,6,7,9	421	= 3,6,8,9	485	= 3,6,7,8,9
294	= 1,3,6,9	358	= 1,3,6,7,9	422	= 1,3,6,8,9	486	= 1,3,6,7,8,9
295	= 2,3,6,9	359	= 2,3,6,7,9	423	= 2,3,6,8,9	487	= 2,3,6,7,8,9
296	= 1,2,3,6,9	360	= 1,2,3,6,7,9	424	= 1,2,3,6,8,9	488	= 1,2,3,6,7,8,9
297	= 4,6,9	361	= 4,6,7,9	425	= 4,6,8,9	489	= 4,6,7,8,9
298	= 1,4,6,9	362	= 1,4,6,7,9	426	= 1,4,6,8,9	490	= 1,4,6,7,8,9
299	= 2,4,6,9	363	= 2,4,6,7,9	427	= 2,4,6,8,9	491	= 2,4,6,7,8,9
300	= 1,2,4,6,9	364	= 1,2,4,6,7,9	428	= 1,2,4,6,8,9	492	= 1,2,4,6,7,8,9
301	= 3,4,6,9	365	= 3,4,6,7,9	429	= 3,4,6,8,9	493	= 3,4,6,7,8,9
302	= 1,3,4,6,9	366	= 1,3,4,6,7,9	430	= 1,3,4,6,8,9	494	= 1,3,4,6,7,8,9
303	= 2,3,4,6,9	367	= 2,3,4,6,7,9	431	= 2,3,4,6,8,9	495	= 2,3,4,6,7,8,9
304	= 1,2,3,4,6,9	368	= 1,2,3,4,6,7,9	432	= 1,2,3,4,6,8,9	496	= 1,2,3,4,6,7,8,9
305	= 5,6,9	369	= 5,6,7,9	433	= 5,6,8,9	497	= 5,6,7,8,9
306	= 1,5,6,9	370	= 1,5,6,7,9	434	= 1,5,6,8,9	498	= 1,5,6,7,8,9
307	= 2,5,6,9	371	= 2,5,6,7,9	435	= 2, 5, 6, 8, 9	499	= 2,5,6,7,8,9
308	= 1,2,5,6,9	372	= 1,2,5,6,7,9	436	= 1,2,5,6,8,9	500	= 1,2,5,6,7,8,9
309	= 3,5,6,9	373	= 3,5,6,7,9	437	= 3,5,6,8,9	501	= 3,5,6,7,8,9
310	= 1,3,5,6,9	374	= 1,3,5,6,7,9	438	= 1,3,5,6,8,9	502	= 1,3,5,6,7,8,9
311	= 2,3,5,6,9	375	= 2,3,5,6,7,9	439	= 2,3,5,6,8,9	503	= 2,3,5,6,7,8,9
312	= 1,2,3,5,6,9	376	= 1,2,3,5,6,7,9	440	= 1,2,3,5,6,8,9	504	= 1,2,3,5,6,7,8,9
313	= 4,5,6,9	377	= 4,5,6,7,9	441	= 4,5,6,8,9	505	= 4,5,6,7,8,9
314	= 1,4,5,6,9	37S	= 1,4,5,6,7,9	442	= 1,4,5,6,8,9	506	= 1,4,5,6,7,8,9
315	= 2,4,5,6,9	379	= 2,4,5,6,7,9	443	= 2,4,5,6,8,9	507	= 2,4,5,6,7,8,9
316	= 1,2,4,5,6,9	380	= 1,2,4,5,6,7,9	444	= 1,2,4,5,6,8,9	508	= 1,2,4,5,6,7,8,9
317	= 3,4,5,6,9	381	= 3,4,5,6,7,9	445	= 3,4,5,6,8,9	509	= 3,4,5,6,7,8,9
318	= 1,3,4,5,6,9	382	= 1,3,4,5,6,7,9	446	= 1,3,4,5,6,8,9	510	= 1,3,4,5,6,7,8,9
319	= 2,3,4,5,6,9	383	= 2,3,4,5,6,7,9	447	= 2,3,4,5,6,8,9	511	= 2,3,4,5,6,7,8,9
320	= 1,2,3,4,5,6,9	384	= 1,2,3,4,5,6,7,9	448	= 1,2,3,4,5,6,8,9	512	= 1,2,3,4,5,6,7,8