

**Building  
and  
Using:**

The Island Keyer II  
from Jackson Harbor Press  
PIC based memory keyer with pot speed control

**General notes about building:** The components should be inserted a few at a time, soldered in place and then the leads are clipped. The pads and traces are small and delicate - a small tipped, low power (25 watts or less) soldering iron should be used.

The integrated circuits (U1 & U2) are CMOS devices. This means that they should be handled as little as possible to prevent static damage. The builder should use a grounding strap and anti-static mat if available or at the very least, work on a grounded metal surface and be sure to touch ground prior to touching the ICs.

**Building the Island Keyer II - Step 1) Get the parts together:** All of the necessary board mounted components have been supplied. You will still have to provide off-board items from the stocklist to fully implement the keyer including the enclosure, speed pot, optional weight and tone pots, memory switches, jacks, battery holder, piezo transducer and mounting hardware. Be sure to get the piezo transducer that requires external drive - basically a very high impedance speaker.

**Step 2) Identify and orient the components:** Most of the components should be fairly easy to identify and place. The .01 uF monolithic ceramic bypass capacitors are very small yellow or blue parts with 2 radial leads spaced .1" apart. You may need a magnifying glass to see the markings on these parts. The four .01 uF bypass caps are marked 103 or .01. The .1 uF monolithic bypass cap is packaged separately from the other parts in the circuit board bag. It is also a small blue or yellow part with 2 radial leads with .1" lead spacing, so it's easy to confuse with the four .01 uF parts. The .1 uF part is marked 104 or .1M. The ceramic resonator is a small blue, white or brown part with three radial .1" spaced leads.

**Step 3) Mount and solder the components on the board:** Use the parts placement diagram along with the parts list (back of this manual) for the placement and orientation of the parts.

Start by inserting the two IC sockets with the small notch towards the left side of the circuit board and then soldering them in place. There is a 1 on the top of the circuit board at the left side of both IC positions.

Then insert the remaining components at the positions shown on the parts placement diagram. Some of the components should only be inserted one way or they can be damaged by reversed polarity. Q1, the output transistor, should be inserted with the flat face to the bottom of the board. The four 1n4148 diodes should be inserted with the black band oriented to the left side of the board. Be sure to solder all the connections and clip leads.

**Step 4) Check your work:** Before proceeding, take the time to check the bottom of the board for solder bridges. Use the Bottom view diagram as a guide to visually check for these shorts. It may help to clean the flux from the board and then use a strong light in conjunction with a magnifying glass to see these problems. Also, double check the

orientation of the critical components such as the diodes and transistor. After you are convinced that the board is OK and after you have formed the leads of ICs U1 and U2 to fit in the sockets, insert the ICs into their respective sockets, being sure to follow the parts placement diagram for proper orientation (pin 1 indicated by a notch or dimple should be to the left. Now hook up the Piezo transducer (speaker) to the connection points on the bottom side of the board (including a connection to ground). Also solder the battery power connections to the top edge of the board.

Next, power up the board. The keyer chip should send an FB powerup greeting through the sidetone if the keyer is functioning correctly. If you don't hear the FB, power down immediately and check again for shorts and/or opens. If the keyer appears functional, then power down and hook the unit up to the switches, pot, paddle & output jacks.

### **Construction Notes:**

Note that the output transistor circuit is designed to switch key inputs of 13.8 volts positive or less. Don't attempt to use the Island Keyer II with a vacuum tube transmitter (either grid block or cathode keyed) without an appropriate outboard circuit - consult older ARRL handbooks for these circuits OR consider using the Keyall kit from Jackson Harbor Press.

The keyer can be powered directly from a 2 or 3 AA or AAA cell battery (3- 4.5 volts). Higher battery voltages will result in slightly louder sidetone and higher supply current usage. The keyer can be operated with or without a power switch - when the keyer is not in use, the power supply current will drop below 2 uA.

The weight and tone pots can be left unconnected since the tone and weight can be set with the command entry. The builder may want to use panel mounted pots (100 K ohms recommended) if the weight and tone will be set often. If the weight and tone will only be set once in a while, the user may elect to use on-board trimpots instead of full sized pots. The circuit board was designed for Panasonic trim pots - these are available from Digi-Key (part number: D4AA15-ND) or contact Jackson Harbor Press (jacksonharbor@att.net) for purchase information. The builder may also opt to mount the trim pots on the bottom of the board if bottom access to the trim pot is required (through a hole in the enclosure). Mounting the trim pots on the bottom will result in the reversal of the control polarity (ex: clockwise rotation will lower the tone frequency).

The pots should be connected to the circuit board per the front view diagram of the pot at the right. The pot connections are shown on the Parts placement diagram. The pot value isn't critical, a 100K linear pot is a good, available choice.

The builder should package the Island Keyer II within an all-metal, grounded case for best results. If strange

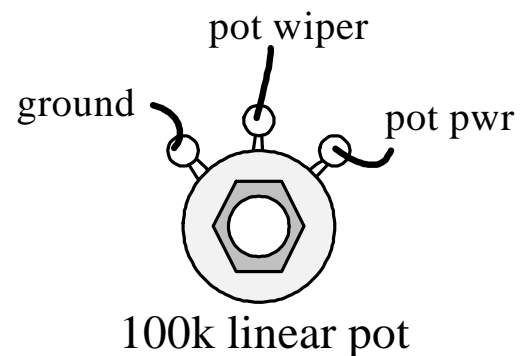

operation is noted during transmit that doesn't occur during disconnected operation, the builder may need to add bypass capacitors and/or series chokes on the various switch, paddle and key inputs to prevent RF from disrupting the keyer chip.

**Operation:** General notes on using the switches to control the keyer: To give the keys multiple functions, multiple key-press combinations are used. Also, the switches can be pressed and released (PAR) OR pressed and held (PAH) for two seconds (duration adjustable by user).

Generally, PAR is used for actions: send the code speed or send a memory. PAH is used for settings: change the code speed (no pot) or record a memory or enter command mode.

There are two non-programmable press and hold commands:

multipress and hold for 2 seconds	function
switches 1 & 2	CE (command entry) mode, exit by sending an E
switches 2 & 3	S (paddle speed set), dit increases speed by 1 WPM, dah decreases by 1 WPM, exit by pressing any mem switch

**Powerup:** Roughly one half second after powerup the keyer will send an FB through the sidetone to signal correct operation. Note that the keyer sidetone defaults to a frequency of about 990 Hz (pitch adjustable by user) for keyer commands such as the command entry prompts, recording a memory or the FB sent at powerup. The default frequency for routine sending or practice is lower at about 600 Hz. Both the command and normal sidetone frequency can be set by the user from 250 to 990 Hz in 10 Hz increments.

**Memories:** The Island Keyer II has a very large number of memories available, 54 total. All are non-volatile - the memory contents will be retained even if power is removed. There are 3 banks of 6 memories in each chapter. There are four chapters in total - note that bank 0 remains the same in each of the four chapters, only banks 1 and 2 change as the chapter is changed. This results in a total of 54 unique memories. The sizes vary but Bank 0 is smallest. Banks 1 and 2 vary but are all larger than bank 0 - see the following table for details. Also note that the memories can be chained together if not long enough using the embedded memory feature.

memory #	response	bank 0 size	bank 1 size	bank 2 size
1	1?	37 characters	255 characters	255 characters
2	2?	37	255	255
3	3?	37	127	127
4	4?	37	127	127
5	5?	37	127	127
6	6?	37	127	127

**General notes on playing memories:** The memories are played with a press and release of the corresponding switch. A tap of either the dit or dah lever will stop (kill) the message

play. PAR the mem key during playback to pause the message at the end of the play of the current character, you can then send manually with the paddles and re-enter the message play with a PAR of the mem key.

Note that there is another mode available for switch presses during a play, the switch presses within a given memory bank can be queued. If CQ were stored in memory 1, DE in memory 2 and callsign in memory 3, switch 1 could be PAR'd 3 times, then switch 2 once, then switch 3 twice and the following would result:

CQ CQ CQ DE callsign callsign

The operator can switch between these two modes via the G oN/oFf command.

Note that when the keyer is in the queued switch mode, a word space will be allowed at the end of any subsequent memory record. This is convenient for separating queued commands. Normally when the keyer is in the pause mode, GF, any word space is deleted from the end of a memory record.

Finally, while in pause mode, if two adjacent memory switches are pressed during a memory play (except for switches 5 & 6), the memory play will be killed.

**General notes on recording memories:** First, select which of the 3 memory banks and 4 chapters you want to record in. Record a memory with a press and hold of the corresponding switch for 2 seconds. The keyer will respond with the characters in column 2 of the table above. The message can then be recorded, exit the recording with a PAR of any memory switch.

The last character recorded in memory can be erased by a PAR of a combination of any of the memory switches and the dit lever. I usually press switch 1, then tap the dit lever, then release switch 1. After the switches are released the keyer will send the last character which is being erased. The embedded commands will play as they are literally recorded - for example: a word space (normally the last "character" recorded and the first character erased) will be sent as didahdahdahdahdit (a dit, 5 dahs and an ending dit). NOTE: last character delete is only for character oriented messages NOT straight key "timed" recordings.

The message can be recorded using either the keyer dit/dah paddles OR by using the straight key. Note that there are two modes for the straight key record. The normal mode (decoded) will attempt to decode the key input and record it as Morse characters. The second mode (see the XN command) will record the key input as timed marks and spaces - this is an attempt to capture the timing of the keyed input.

Gotcha: a recording of switch 6 memories cannot be exited by pressing switch 6 if the straight key is used to record a message - exit the record with a PAR of one of the other memory switches.

**Embedded commands:** Five different embedded commands can be recorded into a message by the user. The question mark is used during recording to allow recognition of these commands by the keyer. Note that the lower case x is actually a number or another letter, not an X. Also note that if there is a need to record a ? in a message, just record two of them in a row, otherwise the keyer will attempt to treat the question mark and the following character as an embedded command.

Embedded command	insert:
?x	another memory into the one being recorded
?P	a pause
?Sxx	speedup to current speed + xx
?Ax	a readout of one of the a/d converter channels
?Dxxxy	a silent delay of xx seconds, y can be any character other than ?
?Dxx?	a key down delay of xx seconds
?N	a serial number play and increment
?F	a slow speed ( /10 or /100 ) play until the end of this memory
?Q	an autoresume pause similar to ?P except play restarts automatically
?Mx	put ?Mx at start of msg, where x is another msg, will play that x message after a given number of plays of the ?Mx message
?Ix	increase the character space by x dit spaces

To insert a memory into the one being recorded, enter ?x where x is the number of the memory to be inserted - if x is the same as the memory being recorded this will result in an endless loop which can be used to create a pseudo beacon. Note that the insertions are done only within the current chapter and bank of memories.

To insert a pause, enter ?P. The keyer will stop at this point during play and allow the manual send via the paddles, play is resumed with a PAR of one of the memory switches.

To insert a speedup, enter ?Sxx where xx is the additional speed - speeds below 10 require a leading zero to be included: send ?S06 to increase the current speed by 6 wpm. After the memory play is complete, the speed will revert to the pot setting (normal speed set). Entering a ?S00 (zero zero) will return the memory play to the normal speed setting.

To insert a readout of one of the a/d converters, enter ?Ax where x is:

S => speed pot input  
 T => tone pot input  
 W => weight pot input.

The keyer will send up to a 4 digit number from 0 to 1023 depending on the input voltage at the particular pin - it does NOT have to be from the pot mentioned - this could be from some external circuit such as a temperature sensor. Note that queued memory switch presses will be ignored during the play of the a/d readout.

To insert a silent delay, enter ?Dxx where xx is the delay in seconds. Y can be any character other than a question mark. Delays below 10 seconds require a leading zero to be included: send ?S05E to embed a 5 second delay into the memory - this can be handy for looped memories (beacon).

To insert a key down delay, enter ?Dxx? the trailing question mark puts the key down.

To insert a serial number play and increment, enter ?N

To insert a slow speed (divide wpm setting by 10 or 100) memory play, enter ?F See the DF command for more information on slow speed sending.

?Q embedded command: inserting a ?Q into a message will result in an embedded pause similar to ?P except that the message play will autoresume after a word is sent. For example:

UR RST IS ?Q QTH IS WASHINGTON ISLAND, WI

The message play would stop after IS and then the keyer will wait until the rst report is sent, such as 5NN - then QTH and the rest of the message will start playing after a word space - only one "word" can be sent since a word space will trigger the auto-resume play.

Inserting a ?Mx at the start of a message (where x is the number of another message memory) will allow the operator to play an alternate message every RStH number of times the button is pressed. x is the number of the alternate message. RS is the number of the repeat factor set with the RS command. For example: if message 1 is loaded with: ?M2TU (no space between 2 and TU) and message 2 is loaded with: WB9KZY UP Then if RS is set to 4, every fourth time button 1 is pressed, it will play WB9KZY UP, all other times it will play TU. If RS is set to 0, message 2 will never be played. If RS is set to 1, message 2 will always be played. RS can be a max of 7.

Inserting a ?Ix in a message (where x is the number of additional dit spaces) will increase the length of subsequent character spaces from the nominal

### **CE - Command Entry:**

CE is the primary way to change the various parameters of the keyer There are two basic actions with CE, first the user can query the keyer about the state of any parameter by sending the one or two character parameter abbreviation by itself. Second, the user can change the parameter setting by sending the one or two character parameter abbreviation along with an N (for oN) or an F (for oFf). OR, the user can send the parameter along with a numerical entry (such as weight percentage or tone frequency). The available commands are listed here in two sections, the first are the numerical entry commands, the second are the on/off commands. Each of the commands is also explained by itself.

Note that the user can enter commands using either the keyer paddles OR with the manual "straight" key.

Note that the keyer will default to exiting the CE loop after a command but staying in the loop after a query. Also note that the keyer will send an error (8 dits) if there is a problem with the command as sent. The user must eliminate extra space between characters of a command (avoid "Farnsworthing") or the keyer will misinterpret the command as a query or simply send an error.

Numerical entry commands:

Command	Query	Explanation
Txx	T	Sidetone frequency, xx => 25 to 99 (250 - 990 Hz), default is 600 Hz
Wxx	W	Weight percentage, xx => 20 to 80 percent, default is 50 %
DDxx	DD	Debounce Delay, xx => 01 to 99 ms, default is 25 ms
BDxx	BD	Beacon Delay time, xx = 00 to 60 seconds, default is 0
CTxx	CT	Command Tone frequency set, x = 25 to 99, default is 99
CSxx	CS	Command Speed set, xx = 06 to 80, default: 00 (plays as 0)
Hxy	H	press and Hold delay time, xy = 01 to 99 (tenths of second) - default is 20 (2 seconds)
1x	1	program the 1 & 2 simulpress, x = 0 to 9
2x	2	program the 2 & 3 simulpress, x = 0 to 9
3x	3	program the 3 & 4 simulpress, x = 0 to 9
4x	4	program the 4 & 5 simulpress, x = 0 to 9
0x	0	program the 1 & 3 simulpress, x = 0 to 9
Nx	N	sets memory bank, x = 0 to 2
Sxx	S	sets speed and sets pot off, xx = 06 to 80
RMx		Record Memory, x = 1 to 6
	PMx	Play Memory, x = 1 to 6, includes literal send of embedded command
SRxyy	SR	A/D pot Speed Range set, xx = low limit, yy = high limit default range is 9 to 39 wpm, max is 80 wpm, min is 06 wpm
SNxxxx	SN	Serial Number set, xxxx = 0000 to 9999, leading zeroes are required
CHx	CH	CHapter set, x = 0 to 3
CLxx	CL	transmitter Compensation Length set, x = 00 to 25 ms, default to 00 ms
DFx	DF	Divide Factor, x = 0, 1 or 2 for wpm divide by 1, 10 or 100 respectively
RSx	RS	Repeat factor Set, x = 0 to 7, 0 turns off feature, x = msg repeat count

**Txx / T - sideTone frequency set / query:** Txx allows the operator to set the sidetone frequency for normal operation. The frequency can range from 250 Hz to 990 Hz - the frequency is entered in 10 Hz steps (drop the third digit). A frequency entered below 25 results in a 250 Hz sidetone setting. A T sent alone will result in the sending of the current sidetone frequency setting followed by a loop back to CE.

**Wxx / W - Weight set / query:** Consider a dit or dah as the mark (key down) plus the space (key up) after it. Normally a dit mark and space are equal in length - this 1:1 ratio can be expressed as a percentage (50%) mark (key down) duty cycle. Wxx allows the operator

to vary this percentage from 20 to 80 percent. Lowering the duty cycle results in a lighter sound - Increasing the duty cycle results in a heavier sounding element. Note that the percentage refers to the dit, but also affects the dah, too. A dah can be thought of as three dit marks (key down) run together followed by a dit space (key up). The weight setting affects only the third dit mark (key down) and the following dit space of the dah. Code speed is unaffected by the weight setting, the same number of dits and dahs will be sent at a given code speed, they will just sound differently. A W sent alone will result in the sending of the current weight setting followed by a loop back to CE.

**DDxx / DD - Debounce Delay set / query:** DD allows the operator to set the debounce delay time for the straight key modes. Mechanical telegraph keys and iambic paddles have contacts which will bounce for a time after the switch is actuated or released. DD defaults to a 25 ms debounce delay time before checking a switch for make/break. This allows the operator to send Morse code at up to 49 WPM or so. However, this delay may be either too short (key bounces for longer than 25 ms) or too long (external keying apparatus may operate at higher than 49 wpm). The Debounce Delay may be set from 0 to 99 ms. To change the debounce delay to nine milliseconds, enter: DD09 (the leading zero is required for debounce delays of less than 10 ms). Note that if the delay is set to zero, the actual resulting delay will be more than 250 ms long which will result in a maximum code speed of less than 5 wpm. A DD sent alone will result in the sending of the current debounce delay setting followed by a loop back to CE.

**BDxx / BD - Beacon Delay set / query:** The beacon delay defaults to a single word space (0 seconds). The maximum beacon delay is 60 seconds. After entering a BD query, the keyer will send the current beacon delay length through the sidetone. To change the beacon delay to five seconds, enter: BD05 (yes, the zero is needed for delays of less than 10 seconds, including 00). Note that the delay times are approximate, roughly 10% long.

**CTxx / CT - Command sideTone frequency set / query:** CTxx allows the operator to set the sidetone frequency for command entry or annunciation. The frequency can range from 250 Hz to 990 Hz - the frequency is entered in 10 Hz steps (drop the third digit). A frequency entered below 25 results in a 250 Hz sidetone setting. Setting a command sidetone frequency completely different than the normal sidetone frequency makes it easy to distinguish when the keyer is in command mode versus normal mode. The default for CT is 99 (990 Hz). A CT sent alone will result in the sending of the current command sidetone frequency setting followed by a loop back to CE.

**CSxx / CS - Command Speed set / query:** CSxx allows the operator to set the speed for command entry or annunciation. The default for CS is 0 which means that the command speed is the same as the normal speed (adjustable by the pot or paddle). To change the command speed to nine wpm, enter: CS09 (the leading zero is needed for speeds of less than 10 wpm, including 00). The allowable command speeds range from 6 to 80 wpm with the addition of 00 for the default tracking command speed. Setting a command speed completely different (usually slower) than the normal speed can make it easier to enter

commands or understand keyer annunciations such as the code speed. A CS sent alone will result in the sending of the current command speed setting followed by a loop back to CE. If the command speed is accidentally set too high, use the keyer reset mentioned at the end in the Notes section to restore the default.

**Hxy / H - press and Hold delay set / query:** The press and hold delay defaults to 2 seconds. Some users may find this either too long or too short, so the delay can be set from .1 to 9.9 seconds. After entering an H query, the keyer will send the current press and hold delay time through the sidetone. To change the press and hold delay to .9 seconds, enter: H09 (yes, the zero is needed for delays of less than 1 second). Note that if the press and hold delay is set to 00, the actual press and hold delay will be well over 20 seconds. Note that the delay times are approximate.

**1x, 2x, 3x, 4x, 0x / 1,2,3,4,0 - PAR multipress set / query:** There are 5 programmable multipress (and release) commands. They are setup initially as follows:

multipress	set (x= 0 to 9)	Alternate simulpress	default function
1 & 2	1x	1 & 4	speed send (command number 0)
2 & 3	2x	2 & 4	command entry routine (CE is sent) command number 1
3 & 4	3c	3 & 5	decrement serial number (command number 3)
4 & 5	4c	2 & 5	increment chapter (command number 9)
1 & 3	0x	1 & 3 (same)	increment the bank (T = bank 0, E = bank 1, I = bank 2) command number 8

These commands may be changed or reordered using the 1x, 2x, 3x, 4x and 0x commands in command entry mode. x can be replaced by one of the following command numbers:

command number	function
0	speed send
1	CE (command entry)
2	tone frequency send
3	decrement serial number
4	enter beacon mode
5	tune
6	bug mode toggle
7	reverse paddle toggle
8	increment the active memory bank (0 => 1, 1 => 2, 2 => 0)
9	increment the memory chapter ( 0 => 1 => 2 => 3 => 0 )

Note that the alternate simulpress set is activated with a simulpress and release of switches 1 and 5. This prevents accidental command entry by touching adjacent switches. The alternate set of simulpresses will continue in effect until the next power down of the keyer. The next power up of the keyer restores the original set of simulpresses.

**Nx / N - memory bank set / query:** Nx allows the operator to set the current memory bank to 0, 1 or 2. The reason for this command is to facilitate the RM and PM commands. N alone queries the current bank setting.

**Sxx / S - Speed set / query:** Sxx lets the user turn off the pot speed control and set the code speed to a constant. This setting is NOT stored in eeprom, so it will not be the same after a power cycle. The maximum speed is 80 wpm, the minimum is 6 wpm.

**RMx - Record Memory set:** RMx lets the user record any of the 6 memories in the current bank.

**PMx - Play Memory set:** PMx lets the user play any of the 6 memories in the current bank. The play also includes whatever special characters (embedded commands) that might be present in the memory.

**SRxxyy / SR - a/d speed pot Speed Range set / query:** SRxxyy allows the operator to set the speed range of the a/d speed pot. The default for SR is 9 to 39 wpm. To change the speed range to 7 to 27 wpm, enter: SR0727 (the leading zero is needed for speeds of less than 10 wpm). An SR sent alone will result in the sending of the current a/d pot speed range setting followed by a loop back to CE. The maximum speed is 80 wpm, the minimum is 6 wpm.

**SNxxxx / SN - Serial Number set / query:** SNxxxx allows the operator to set the starting serial number. The powerup default for SN is 0. To change the serial number to 17, enter: SN0017 (the leading zeroes are needed for serial numbers of less than 1000. The maximum count is 9999. The serial number may be inserted into a memory using the ?N embedded command. The serial number may be decremented easily using the default 3+4 multipress - this allows to the user to easily repeat a serial number message if needed OR disregard a duplicated contact.

**CHx / CH - CHapter set / query:** CHx allows the operator to set the current memory chapter to 0, 1, 2 or 3. Note that the memory bank doesn't change when the chapter is set. Also note that the chapter only applies to banks 1 and 2 (external eeprom), Bank 0 is always the internal eeprom of the keyer chip. The reason for this command is to facilitate the RM and PM commands. CH alone queries the current bank setting.

**CLxx / CL - transmitter Compensation Length set / query:** CLxx (where xx can equal 00 to 25 ms) allows the operator to extend the length of any dit or dah sent by that many milliseconds. CL is for those operators who feel that their transmitter is shortening code elements. CL is independent of the weight setting and is NOT reflected in the sidetone. Note that the CL setting in combination with the speed setting and/or weight setting may result in bizarre output from the keyer when the mark length exceeds the normal mark + space length. CL alone queries the transmitter compensation length setting which defaults to 0.

**DFx / DF - Divide Factor set / query:** DFx (where x can equal 0, 1 or 2) allows the operator to set the speed divide factor to 1, 10 or 100 respectively. The divide factor is used with the ?F embedded command and allows very slow message / beacon play. Normally the message would be entered and played with DF set to 0 to allow the operator to verify the message contents. Then the DF could be set to either 1 or 2 to allow the slow speed play of the memory. So, with a speed range of 6 to 80 wpm, the operator can choose to send a memory or beacon at .6 to 8 wpm in .1 wpm increments with DF set to 1 OR at .06 to .80 wpm in .01 wpm increments. DF alone queries the current divide factor setting. Note that exiting from a currently playing slow speed message with a dit/dah/key press may be frustrating because the bailout will take until the current element and element space are completed.

**RSx / RS - Repeat factor Set / query:** RFx (where x can equal 0 to 7) allows the operator to set a repeat factor for use with the ?Mx embedded command mentioned previously. x=0 turns off the ?Mx embedded command.

One interesting feature of the Island Keyer II is the ability to connect two pins of the keyer chip, via two 2n7000 transistors (as shown here:)

Island Keyer II paddle output circuit  
(output from the IK2 to another keyer paddle inputs)

1/22/2005 WB9KZY

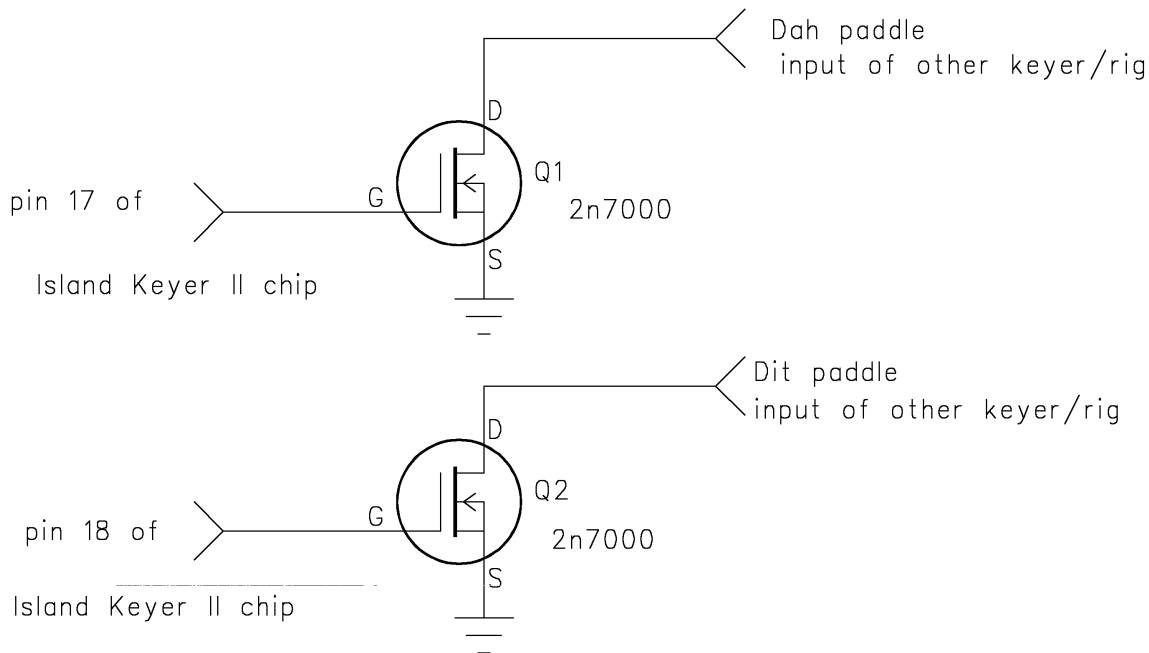

to another keyer or rig with a built in keyer. These outputs will be actuated during a memory play and will “key” the external keyer. This allows the operator to transfer memories from the Island Keyer II to another keyer. One

user who was unfamiliar with iambic keying wanted to be able to use this feature to record memories on the Island Keyer II using the straight key and then transfer these memories to the other keyer within a rig, which allowed him to avoid the need to learn the iambic mode but still be able to use the Morse memories within his rig

Table of On / Off Commands:

Command	Query	Explanation	Default
E		Exits command entry mode	
TU		enters TUne mode	
BE		enter BEacon mode	
BAN BAF	BA	Beacon Alternate oN or oFf	off
BPN BPF	BP	Beacon Powerup oN or oFf (on => beacon at powerupt)	off
BKN BKF	BK	Beacon Key down oN or oFf (for fox FM transmitter hunts)	off
KN KF	K	Key down beacon delay oN or oFf	off
BN BF	B	Bug mode (Ele-bug) oN or oFf (dit = normal, dah = straight key)	off
UN UF	U	Ultimatic mode oN or oFf (non-iambic dual lever keying mode),	off
LN LF	L	Live recording mode oN or oFf	off
PN PF	P	Practice mode oN or oFf (keyer output is turned OFF)	off
AN AF	A	Iambic mode A oN or oFf (when mode A is off, mode B is ON),	off
BCN BCF	BC	iambic mode B emulation of Cmos super keyer	off
RN RF	R	Reverse paddles oN or oFf (dit lever becomes the dah lever),	off
STN STF	ST	SideTone oN or oFf (sidetone will still occur during commands),	on
SFN SFF	SF	Sidetone Float oN or oFf (on => reduces thump)	off
DIN DIF	DI	DIt memory oN or oFf	on
DAN DAF	DA	DAh memory oN or oFf	on
AUN AUF	AU	AUtospace oN or oFf	off
SSN SSF	SS	Speed Send after paddle speed set oN or oFf	off
PON POF	PO	POt speed control oN or oFf	on
MN MF	M	Multiple commands oN or oFf, allows CE loop for commands,	off
FN FF	F	Fast command entry, turns off the CE, ON => E, OFF => T,	off
YN YF	Y	a/d tone pot oN or oFf	off
ZN ZF	Z	a/d weight pot oN or oFf	off
	V	sends firmware version	
ON OF	O	turn bank (and chapter) send after increment oN or oFf	on
XN XF	X	straight key record oN or oFf	off
GN GF	G	switch press queue oN or oFf (off => pause/kill)	off
SPN SPF	SP	Stuck Paddle timeout oN or oFf	on
5N 5F	5	5 didah (or 9 dah) entry into CE oN or oFf	off

**E - Exit command entry mode:** If the operator enters an E alone the keyer will exit the command entry (CE) routine. An alternate way to exit the CE routine is to PAR any of the six memory switches.

**TU - Tune Mode:** If the operator enters TU, the keyer will enter a TUNE mode, the output will turn on and the sidetone will go on. Exit tune mode with a PAR of any memory switch, paddle or key.

**BE - Beacon Mode:** Beacon mode will send the contents of mem 2 continuously with a selectable (see BD command) pause in between each play of the memory. Start the beacon by sending BE in the command entry mode - the beacon starts to play. Exit beacon mode by tapping the dit or dah lever. The powerup beacon mode will start the beacon right after the FB is sent after turning on the power to the keyer.

**BAN BAF / BA - Beacon Alternate between mem 1 and mem 2 mode oN / oFf / query:** BAN will turn oN alternating the beacon between mem 1 and mem 2. BAF will turn oFf the alternation - the beacon will repeat mem 1 only. BA alone asks the keyer if the beacon alternate mode is now on or off.

**BPN BPF / BP - Beacon Powerup oN / oFf / query:** BPN will set the keyer so that when it is turned on, the keyer will send FB as usual and then immediately enter beacon mode, BPF will turn off this mode (default).

**BKN BKF / BK - Beacon Keydown oN / oFf / query:** BKN will allow the operator to use the Island Keyer II as a fox FM transmitter beacon. The key output will go low and stay low throughout a beacon send. This allows the operator to connect the key output to the PTT line of an FM transmitter. The sidetone output is then coupled (through an appropriate filter / attenuator) to the rig microphone input. Note that the sidetone frequency used with BKN is the Command Sidetone frequency, so CS should be set to an appropriate frequency.. There is about a 1 second delay between the last character sent by the beacon and when the key output goes high. Unless a Beacon Delay is set, the key will stay down continuously. Enter BKF to turn off the keydown setting. BK alone queries whether the keydown setting is on or off.

**KN KF / K - Key down beacon delay oN / oFf / query:** Enter KN to turn oN the key down beacon delay mode. This will enable the sending of a constant key down during the interval between sending the beacon message. Enter KF to turn oFf (return to the default) the key up beacon delay. K alone asks the keyer if the key down beacon is now on or off.

**BN BF / B - Bug mode oN / oFf / query:** Bug mode (also known as Ele-bug) is where dits are sent normally but dahs are sent like a straight key. A BN will turn on bug mode, BF turns it off (default) and B alone inquires whether bug mode is currently on or off.

**UN UF / U - Ultimatic mode oN / oFf / query:** Ultimatic is a dual lever keying mode which predates the now popular iambic A/B modes. Ultimatic differs in this way from iambic: instead of an alternation between dit and dah when both levers are pressed, ultimatic will output the element of the last lever pressed. This can be handy for sending characters such as the ? (press and hold the dit for 2 dits, then while keeping the dit pressed, press the dah for 2 dahs, then release the dah for the last two dits). Note that Ultimatic setting takes

precedence over either the iambic modes. A UN will turn on ultimatic mode, UF turns ultimatic off (default) and U alone queries the keyer as to whether ultimatic mode is currently in use.

**LN LF / L - Live or Dead recording oN / oFf / query:** Normally, the memory or callsign will be recorded by the user off the air (dead) but sometimes it's desirable to be able to record a message on the air (live). LN will turn on live recording, LF turns it off (default) and L alone will inquire whether the keyer is currently in live recording mode or not.

**PN PF / P - Practice mode oN / oFf / query:** Practice mode is where the output transistor is not keyed but the sidetone is retained. This allows the user to get used to the keyer without having to disconnect the rig. Note that PR takes precedence over the ST menu item - even if the sidetone is turned off with ST, turning on the practice mode with PR will re-enable the sidetone. PRN turns on practice mode, PRF turns it off (default) and PR alone inquires whether the keyer is currently in practice mode.

**AN AF / A - Iambic mode A or B oN / oFf / query:** The A mentioned above signifies the mode A/B select menu item. The iambic mode of the keyer can be set to either mode using this routine. Check the JHP web site for an Acrobat (.pdf) file which explains the difference between the A and B keying modes. AN turns on mode A, AF returns the keyer to mode B (the default) and A alone inquires whether the mode A is on or off. Note that either iambic mode is overridden if ultimatic mode is turned on.

**BCN BCF / BC - iambic mode B emulation of Cmos super keyer:** This item attempts to emulate the iambic B keying mode of the CMOS Super Keyer from QST of October of 1981. The difference between the default iambic mode B and the CMOS Super keyer iambic mode B is that dit input is ignored during the first 1/3 of a dah period. This is supposed to allow the operator a little more time to "get off" the dit paddle without latching in another dit after the dah currently being sent.

**RN RF / R - Reverse paddle mode oN / oFf / query:** Reverses the dit and dah levers (easier than resoldering a jack). RN reverses the dit and dah paddles, RF returns the dit and dah paddles to the default (wired) state and R alone inquires whether the paddle reverse has been turned on.

**STN STF / ST - SideTone oN / oFf / query:** The sidetone will still be engaged during any menu or recording entry and during practice mode even if it is turned off with this menu item - this item allows the user to employ his rig sidetone. STN turns on the keyer sidetone (default), STF turns off the keyer sidetone and ST alone inquires whether the sidetone is now on or off.

**SFN SFF / SF - Sidetone Float oN / oFf / query:** The reason for floating the sidetone pin is to minimize thump from the sidetone if the Island Keyer II sidetone is injected into a rig audio chain. The float should normally be DISABLED when using a piezo sidetone in a standalone keyer to prevent excessive power supply current in the sleep mode. SFN turns on

the sidetone float condition, SFF turns the sidetone float off (default) and SF inquires whether the sidetone float is now on or off.

**DIN DIF / DI - DI memory oN / oFf / query:**

**DAN DAF / DA - DAh memory oN / oFf / query:** Normally the keyer has both dit and dah memories enabled - at higher speeds (30 WPM or more), some users may like “less” memory. The dit and dah memories are evident if the dit and dah paddles are pressed rapidly in order at low speed. If the dah memory is on, an A will be sent. If the dah memory is off, an E (single dit) is sent. DIN turns on the dit memory (default) - DAN turns on the dah memory which is also the default state of the keyer. DIF or DAF will turn off the respective memory and DI or DA alone will query the keyer as to whether the memory is now on or off.

**AUN AUF / AU - AUtospace oN / oFf / query:** The autospace feature inserts a character space (1 dah in length) automatically if the operator has not pressed a paddle switch 1 dit space after the last dit/dah sent. This feature is always on in the memory record routines (needed for the recording process). An AUN turns on the autospace mode, AUF turn it off (default) and AU alone asks the keyer whether autospace is now on or off.

**SSN SSF / SS - Speed Send oN / oFf / query:** This menu item controls the speed send at the end of the paddle speed set menu item. This was requested by a PK-3 user who felt the speed send took too long and was not needed. An SSN will turn on the speed send (default), an SSF will turn it off and SS alone inquires as to the current status (on or off) of speed send.

**PON POF / P - Select Pot or Paddle speed control oN / oFf / query:** If the keyer is accidentally put into the paddle speed control mode the pot speed control can be resumed with a PON command. The keyer defaults to the speed pot on (if it is connected) - a POF turns off the pot speed control. PO alone will ask the keyer if the pot speed control is now on or off.

**MN MF / M - Multiple command entry oN / oFf / query:** MN will turn on the multiple command entry mode - after a command is entered the user will hear CE which means that another command can be entered. This can be handy if a number of changes are required at the same time. Exit the multiple command mode with an E. MF turns off the multiple command mode (default) - after a command is entered the keyer immediately returns to normal keying mode. M alone asks the keyer whether the multiple command mode is on or off.

**FN FF / F - Fast command entry oN / oFf / query:** FN turns on the fast command mode where the sending of CE is eliminated - also, now the keyer will send an E instead of ON and the keyer will send a T instead of OFF. The operator still needs to send an N or F to perform the on or off command entry. FF turns off the fast command mode and F alone asks the keyer to send either the on or off state of fast command mode.

**YN YF / Y - a/d tone pot oN / oFf / query:** In addition to being able to set the sidetone frequency using the T command entry, the operator can connect a pot to the a/d pot input of the Island Keyer II and vary the sidetone of the keyer at will, in the same way the speed can be set using the a/d speed pot. YN turns on the a/d tone pot. YF turns off the a/d tone pot (default) - the current tone setting will be saved when the a/d tone pot mode is exited. Y alone asks the keyer whether the tone pot is now on or off.

**ZN ZF / Z - a/d weight pot oN / oFf / query:** In addition to being able to set the weight using the W command entry, the operator can connect a pot to the a/d pot input of the Island Keyer II and vary the weight of the keyer at will. ZN turns on the a/d weight pot. ZF turns off the a/d weight pot (default) - the current weight will be saved when the a/d weight pot mode is exited. Z alone asks the keyer whether the weight pot is now on or off.

**V - Version query:** V asks the keyer to send the current version of the firmware.

**ON OF / O - bank/chapter send after increment oN / oFf / query:** ON will set the keyer so that when a bank is changed, a short character is sent to signify which bank (or chapter) is in use. T is sent for bank/chapter 0. E is sent for bank/chapter 1. I is sent for bank/chapter 2. S is sent for chapter 3. OF will turn off this character send when the bank/chapter is selected (via the multipress).

**XN XF / X - timed straight key record oN / oFf / query:** Normally when the straight key is used to record a memory, the keyer decodes the sending and stores it as characters as it does with the paddle entry. XN turns on a different, timed straight key record mode. The keyer will now record the straight key input as timed mark and space bytes. This will decrease the number of characters that can be recorded but attempts to give a little flavor of the straight key timing that the particular user has. XN will also turn off the paddle for recording of a memory. XF returns the keyer to the default to the decoded straight key record mode. The pot setting has no effect on the playback speed of a memory recorded with the keyer in XN mode. Note that the paddle remains active with XF (keyer in the normal straight key recording mode). X alone queries the keyer as to the current straight key recording mode. This mode is restricted to chapter 0 memories only - if XN is set and a chapter 1,2 or 3 memory is being recorded with the straight key, the keyer will revert to the decoded mode for storing the message.

**GN GF / G - switch press queue oN / oFf / query:** GN allows the user to queue a series of switch presses (note that these also include multipresses). GF (default) turns off the queue mode and allows the user to pause a message during play with a switch press. GF also allows the user to kill a message play with any multipress of memory switches. Note that switch presses CANNOT be queued during a serial number play, an embedded A/D value play or a speed send.

**SPN SPF / SP - Stuck Paddle timeout oN / oFf / query:** This item puts the keyer to sleep after 128 consecutive dits, dahs or didahs - which normally will only occur when one

or both of the paddles are stuck on. SPN turns on the stuck paddle timeout test (default), SPF turns off the stuck paddle timeout test and SP alone inquires whether the stuck paddle test is now on or off.

**5N 5F / 5 - 5 ditdah (or 9 dah) entry into CE oN / oFf / query:** This item provides an alternate way to enter command entry (CE) mode is by sending 5 (or more) continuous ditdahs or 9 (or more) continuous dahs and then releasing the paddle. The keyer will then enter command entry mode. Note that the 5 ditdahs or 9 dahs will be sent live over the air. 5N turns on this mode, 5F turns off the this mode (default) and 5 alone inquires whether the mode is now on or off.

### **Notes:**

To perform a full keyer reset (all parameters to their default values):

- 1) remove power to the keyer
- 2) press the dit or dah (you may hear a short blip on the sidetone)
- 3) powerup the keyer with mem switch 2 depressed until the FB is sent.
- 4) release the mem switch - the keyer should now be reset to it's defaults

The bypass capacitors across the power and ground circuits of the keyer can sometimes retain enough voltage to prevent the above keyer reset from being successful. If this occurs, power off the keyer and then short out the bypass capacitors (including the ones on the input of any voltage regulators). This will allow the full keyer reset to take place.

Table of initial contents of Island Keyer II memories:

Chapter	Bank	switch 1	switch 2	switch 3	switch 4	switch 5	switch 6
0	0 *	FB HI **	TTTT	TTTT	TTTT	TTTT	TTTT
	1	1C0	2C0	3C0	4C0	5C0	6C0
	2	1IC0	2IC0	3IC0	4IC0	5IC0	6IC0
1	1	1C1	2C1	3C1	4C1	5C1	6C1
	2	1IC1	2IC1	3IC1	4IC1	5IC1	6IC1
2	1	1C2	2C2	3C2	4C2	5C2	6C2
	2	1IC2	2IC2	3IC2	4IC2	5IC2	6IC2
3	1	1C3	2C3	3C3	4C3	5C3	6C3
	2	1IC3	2IC3	3IC3	4IC3	5IC3	6IC3

\* Bank 0 contents are the same for each of the four chapters

\*\* The HI is sent at 15 WPM faster than current speed (see the ?Sxx embedded command)

Note that the TTTT entries are sent with increasing char space delay from I=0 to 4 (see ?Ix)

The external eeprom memory contents (banks 1 & 2) are automatically loaded by the keyer chip if memory switch 4 is pressed at powerup. The initial digit signifies the memory switch. The I refers to bank 2. The Cx shows the chapter.

Most of the features in the keyer were the result of suggestions from PK-3 users. Please feel free to email with any questions, comments, suggestions or problems with the keyer- email to: [jacksonharbor@att.net](mailto:jacksonharbor@att.net)

Best Regards and thanks for choosing the Island Keyer II, Chuck Olson, WB9KZY

## Island Keyer II Kit Parts List

<u>Qty</u>	<u>Ref</u>	<u>Part Name</u>	<u>Description</u>
1	U1	16F876	Island Keyer II programmed 28 pin DIP PIC microcontroller
1	U2	24LC64	8 pin DIP serial EEPROM memory
1	X1	CERES	4 Mhz ceramic resonator
1			8 pin socket
1			28 pin socket
1			circuit board
1	Q1	NPN	NPN bipolar keying transistor
4	D1-4	1N4148	diodes
1	C2		.1 uf bypass capacitor - multilayer ceramic
4	C1,3-5		.01 uf bypass capacitor - multilayer ceramic
3	R1,2,7		10 K ohm resistor - brown-black-orange-gold
1	R3		4.7K ohm resistor - yellow-purple-red-gold
1	R8		750 ohm resistor, violet-green-brown-gold, small 1/8 watt

The following items are **NOT** included with the kit:

6	SW1-6		normally open momentary switch
1	R4		100 K speed pot
2	R5, R6		100 K weight, tone pots
1	piezo		piezo sounder (sidetone)
1			stereo paddle jack
1			mono key jack
1			mono output jack
1			battery holder, 3V or 4.5V

The following items are available as an optional extra with the kit:

1	Q1	2n7000	MOSFET keying transistor (lowers keyer active current usage) same pinout / orientation as NPN transistor shown on schematic
2	R5, R6		Panasonic 100 K weight and tone on-board trim pots

Copyright © 2006 by Charles J. Olson, WB9KZY  
Jackson Harbor Press  
[jacksonharbor@att.net](mailto:jacksonharbor@att.net)